

DUAL UPRIGHT CHILLER/FREEZER

- Blower System
- Magnetic Solid Door



4DU-2F2C

4 DOOR

MODEL

		4DU-2F2C
Temperature°C (celsius)	- Chiller	+1 to +4
	- Freezer	-22 to -18
External Dimension (mm)		1300 x 760 x 2000
Internal Dimension (mm)	- Chiller	540 x 640 x 1460
	- Freezer	540 x 640 x 1460
Gross Volume (Litres)	- Chiller	504
	- Freezer	504
Voltage/ Frequency (V/ Hz)		230V/1/50Hz 220V/1/60Hz
Weight (kgs)		182
Compressor	- Chiller	1/4Hp
	- Freezer	1/2Hp
Wattage (W)		1188 - 1312
Ampere (A)		7.0 - 7.8
Energy Consumption (kw/ 24h)		19.5 - 21.5
Refrigerant/ Grams	- Chiller	R134a / 280g
	- Freezer	R404a / 570g
Defrost System		Forced Air Circulation / Electric Heater
Temperature Control		Digital
Shelves (Pvc)		8
Number Of Clips		32

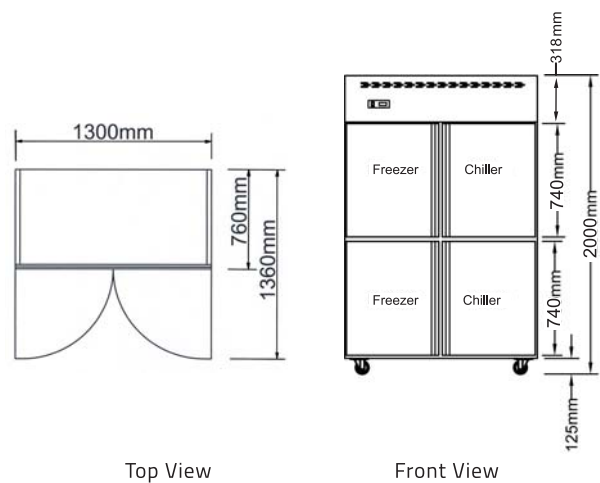

*Note:-
 Option : CW - Castor Wheel / BF - Bullet Feet

As product improvement is an on going process, we reserve the right to change specifications or design without notice.